

## Full Function Syncro Control

**-19C**

(Back & Seat Rock/Lock in a 2:1 Ratio)

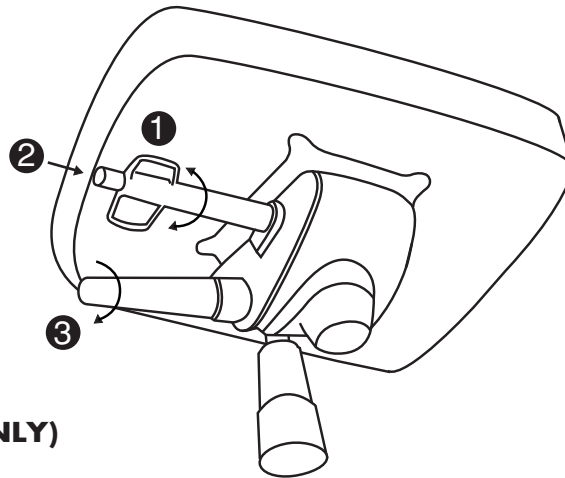

### TASK CONTROL (RIVA CHAIR ONLY)

Adjustments described from seated position.

- 1 **Seat Height Adjustment** - Located right center below seat. To raise the chair, lift your weight from the chair and rotate paddle clockwise. To lower, remain seated and rotate the paddle clockwise.
- 2 **Five Position Back Angle Lock** - Tilt the seat back to desired angle. Push and release button to lock. To unlock back, push in and release button and lean back.
- 3 **Back/Recline Tension** - From seated position, take pressure off back (lean forward) turn clockwise to tighten and counter clockwise to reduce back tension.