

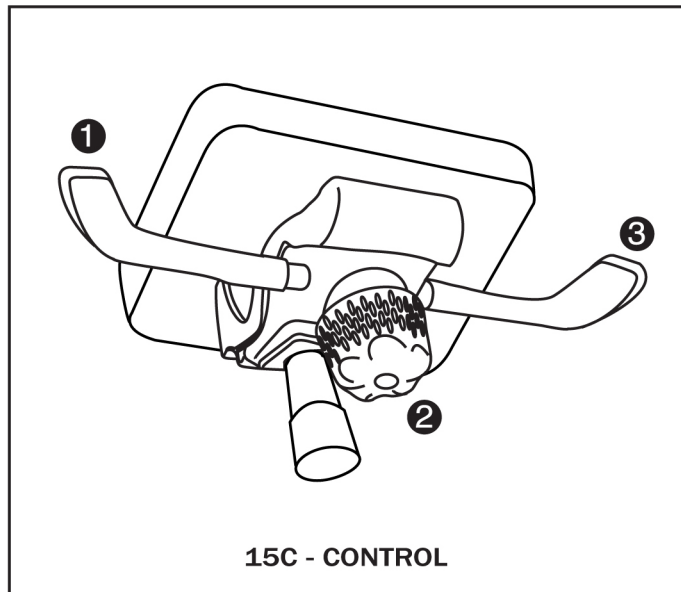

Two Paddle Tilt, Six Position Lock Control

Available for the Dyce chair only

All references to left or right are from the seated position



① **Seat Height** - To raise the chair; lift your weight from the chair and lift the lever. To lower the chair; while seated, lift the lever upward, lower to desired height. Release lever to lock the chair at the desired height.

② **Back Angle Lock** - Tilt the seat back to desired angle and lift lever. The back will lock in six positions. To unlock push lever down lean back and pull forward.

③ **Tilt/Recline Tension** - Turn clockwise to tighten and counter clockwise to lessen back tension.